

Product Specification

Material

Brass Material, Black Matte & Chrome Finished

Product Capability

Cartridge : Mixer Ceramic Cartridge Sedal
 Durable test : 70.000 cycles
 (Based on EN817 : 2008)
 Maximum Pressure : 7 kg/cm²
 Maximum Temperature : 90°C
 Working Pressure : ½ - 4 kg/cm²

Package Include

Brass Body
 Hot & Cold Flexible Hoses
 Locking Nut & Seals

PUB Approved

Water Efficiency : Very Good ✓✓
 Water Consumption : 3.90 liter/min
 Registration No : BST-2019/025842/SLS

Product Features

Hot & Cold
 NEOPERL Aerator
 PVD Coated Painting



Technical Drawing

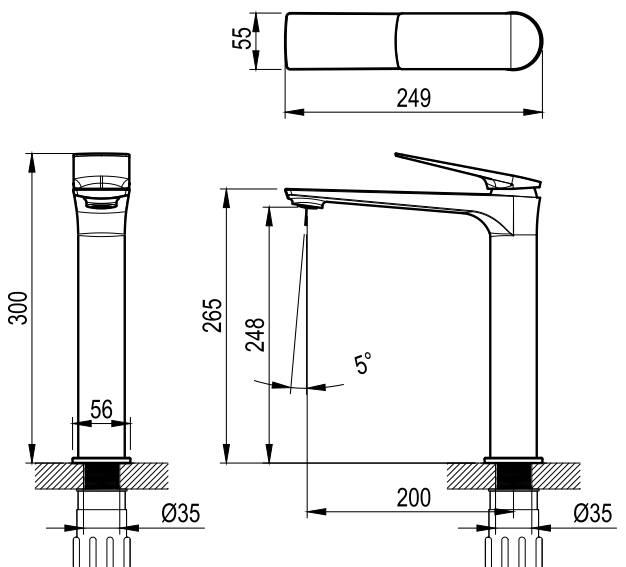

Installation Details

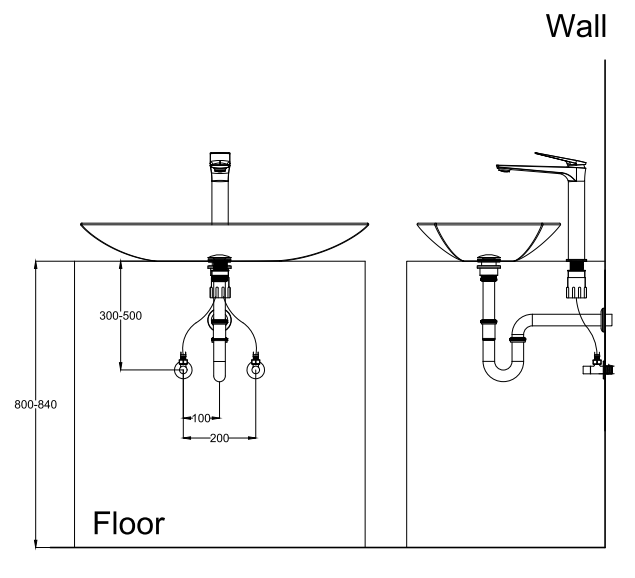

Disclaimer : While we endeavor to provide the most accurate, up-to-date information available, the content on this document may be change due to requirements in different sites, markets and/or countries, out of date or include omissions, inaccuracies or other errors. All content is subject to change without prior notice.